

| Pos.-Nr. | Zeichnung Nr. | Benennung | Material | Revision | Menge |
|----------|------------------|----------------------|----------|----------|-------|
| 1 | 13-04-12-1600-01 | Stab Ø1,0 | 1.4441 | A | 1 |
| 2 | 13-04-12-1600-02 | Schieber für St.Ø1,0 | 1.4305 | A | 1 |
| 3 | 13-04-12-1600-03 | Kopf | 1.4305 | A | 1 |
| 4 | 13-04-14-1800-04 | Rohr | 1.4301 | A | 1 |
| 5 | 13-04-14-1800-05 | Schutzhülse | 1.4301 | A | 1 |
| 6 | 13-04-20-1800-03 | Mutter | 1.4305 | A | 1 |
| 7 | Kugel Ø4 | Kugel Ø4 | 1.4034 | - | 1 |
| 8 | VD-053A | Druckfeder | 1.4310 | - | 1 |

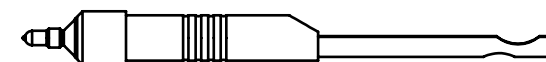

M1:2

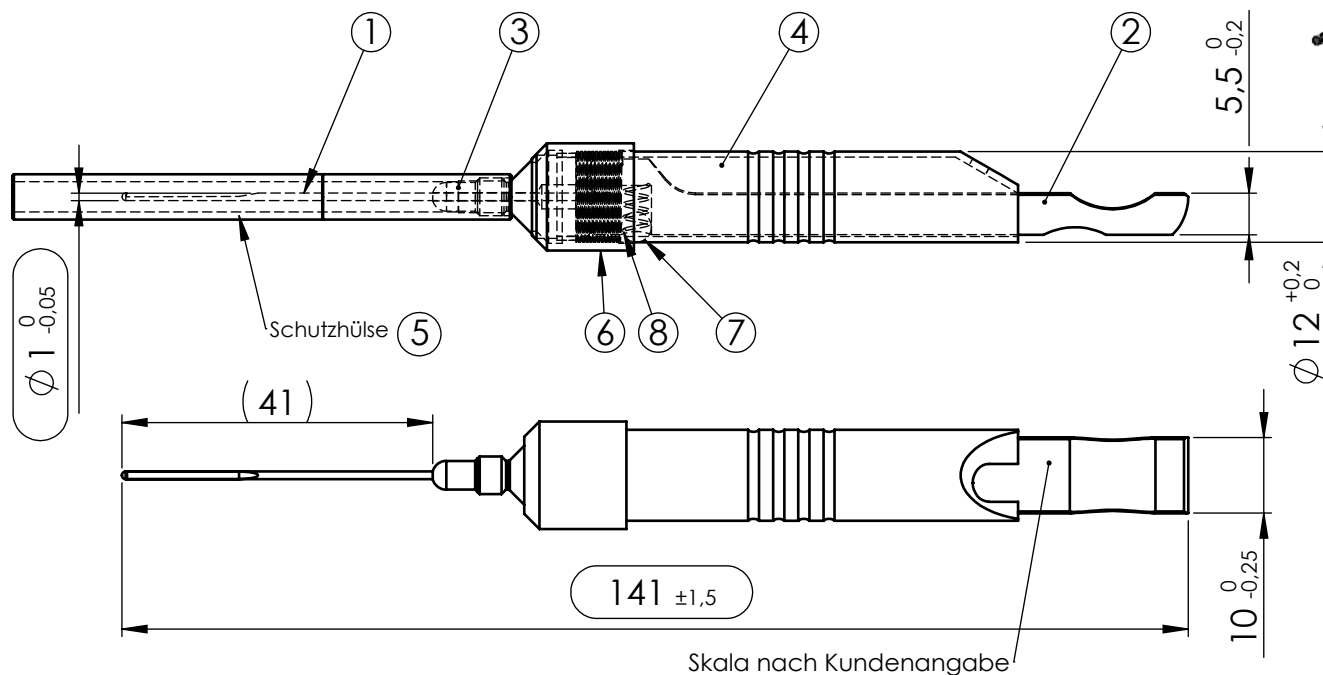
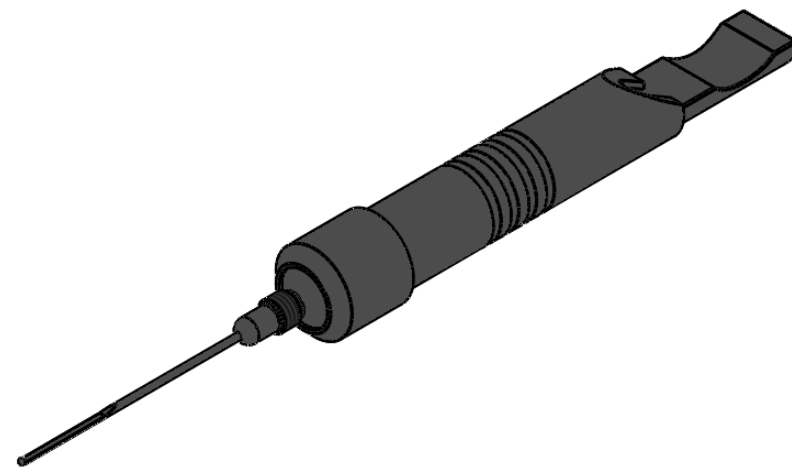
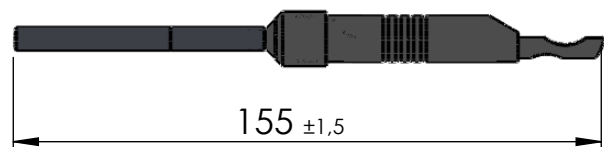

M1:2

NON DISCLOSURE AGREEMENT

This drawing and / or specification contains information confidential and proprietary to SMT Schilling Metalltechnik GmbH Germany; and is conditionally loaned only. By retention, the receipt agrees not to reproduce or copy it in whole or in part, disclose any or all of its contents without prior written permission, or to make any use of it contrary to SMT Schilling Metalltechnik interest.

SMT - Werkszeichnung; entspricht nicht nach DIN

| | | | | | |
|-------------------------------|---------------------|---|---|---|------------|
| (Verwendungszweck) - | | (Zul. Abweich.) DIN ISO 2768m | (Oberfl.) Glasperlen- gestrahlt | Maßstab 1:1 | Revision A |
| Toleranzen (mm) DIN ISO 2768m | | | | (Werkstoff, Halbzeug, Rohteil-Modell-Gesenk-Nr.) Material siehe Stückliste | |
| bis 6 | 6-30 | 30-120 | 120-400 | 400-1000 | |
| $\pm 0,1$ | $\pm 0,2$ | $\pm 0,3$ | $\pm 0,5$ | $\pm 0,8$ | |
| | | DIN 6 T1 Proj.methode 1 | | BENENNUNG: | |
| | | DATUM | NAME | Tiefenmaß für Mini-Schrauben | |
| | | Erst. 09.01.2015 | M.Diener | | |
| | | Gep. 09.01.2015 | Ovsjannikov | | |
| | | Freig. 09.01.2015 | E.Schilling | | |
| A | Zeichnung erstellt. | 09.01.15 | MD | ZEICHNUNGSNR. 13-04-12-1600 | |
| Zust. | Änderung | DATUM | NAME | Blatt 1 1 VON 1 | |