

Position	Menge	Bennennung	Artikel-Nr.	Material:	Revision
1	1	Ferrozell-Griff	73-01-11-2705	Ferrozell	A
2	1	Stift	30-01-22-1614-02	1.4441	A
3	1	Welle	30-01-22-1614-03	1.4301	A
4	1	Platte	30-01-22-1614-04	1.4404	A
5	1	Einsatz	30-01-22-1614-05	1.4404	A

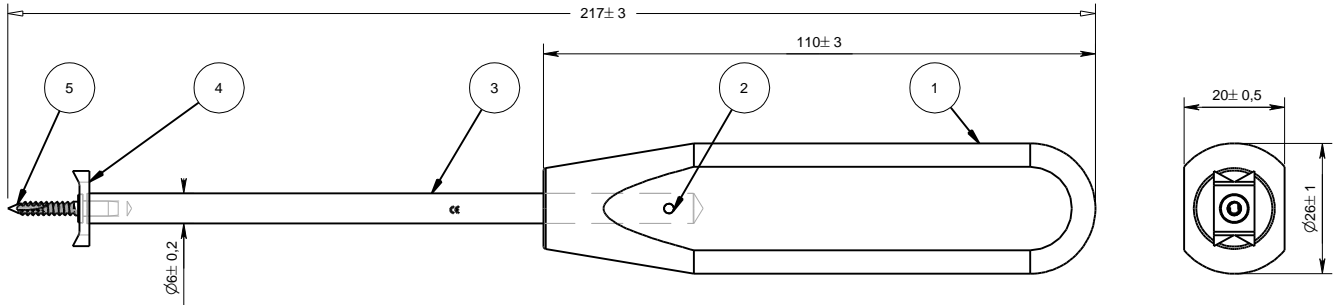
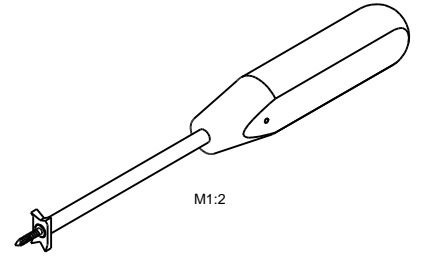

NON DISCLOSURE AGREEMENT

This drawing and / or specification contains information confidential and proprietary to SMT Schilling Metalltechnik GmbH Germany, and is conditionally loaned only. By retention, the recipient agrees not to reproduce or copy it in whole or in part, disclose any or all of its contents without prior written permission, or to make any use of it contrary to SMT Schilling Metalltechnik interest.

SMT - Werkzeichnung; entspricht nicht nach DIN

		(Zul. Abweich.) ISO 2768-m	(Oberfl.) Glasperlen- gestrahlt 70-110 µ	Maßstab 1:1	Revision B
		Datum	Name	(Werkstoff, Halbzeug, Rohteil- Modell- Gesenk-Nr.) Material Siehe Einzelteile	
		Bearb: 17.04.15	A. Stuwe	Holder bone graft 8-1/2"	
		Gepr: 17.04.15	E. Schilling		
		Anzahl / Einheit: 1 St. 1		(Benennung)	
		SMT Schilling			(Zeichnungsnummer)
		Metalltechnik GmbH			30-01-22-1614
		Ers. für:			Ers. durch:
B	Beschriftung geändert.	17.04.15	STA	Blatt 1	
A	Zeichnung erstellt.	11.05.12	STA	Blätter	
Zust.	Anderung	Datum	Name	Urspr.	