

Pos-Nr.	MENGE	Art.Nummer	Benennung	Material	Revision
1	1	30-01-18-1601-09	Zwischenscheibe	1.4301	A
2	1	30-01-20-1601-03	Branche fest	1.4301	A
3	1	30-01-20-1601-04	Branche beweglich	1.4301	A
4	1	30-01-20-1601-05	Lösehebel	1.4301	A
5	1	30-01-20-1601-08	Gelenkschraube	1.4404	D
6	1	30-01-20-1601-10	Mutter	1.4305	A
7	4	30-01-20-1601-11	Bundniete 7x5x9,5	1.4301	A
8	1	30-01-20-1601-12	Bundniete 5x3,2x12,5	1.4301	A
9	1	30-01-20-1601-13	Druckstück	1.4021	A
10	1	30-01-20-1601-32	Mittelteil	siehe Stückliste	A
11	1	30-01-25-1601-01	Backen fest	1.4021	B
12	1	30-01-25-1601-02	Backen beweglich	1.4021	B
13	1	30-01-25-1614-01	Stellschraube M8	1.4305	A
14	1	3000650	Schenkelfeder 1,0 x 5,2 DiX 2,2	1.4310	A
15	1	13000653	Zugfeder mit Öhsen	1.4310	-

Branche fest (M1:1):

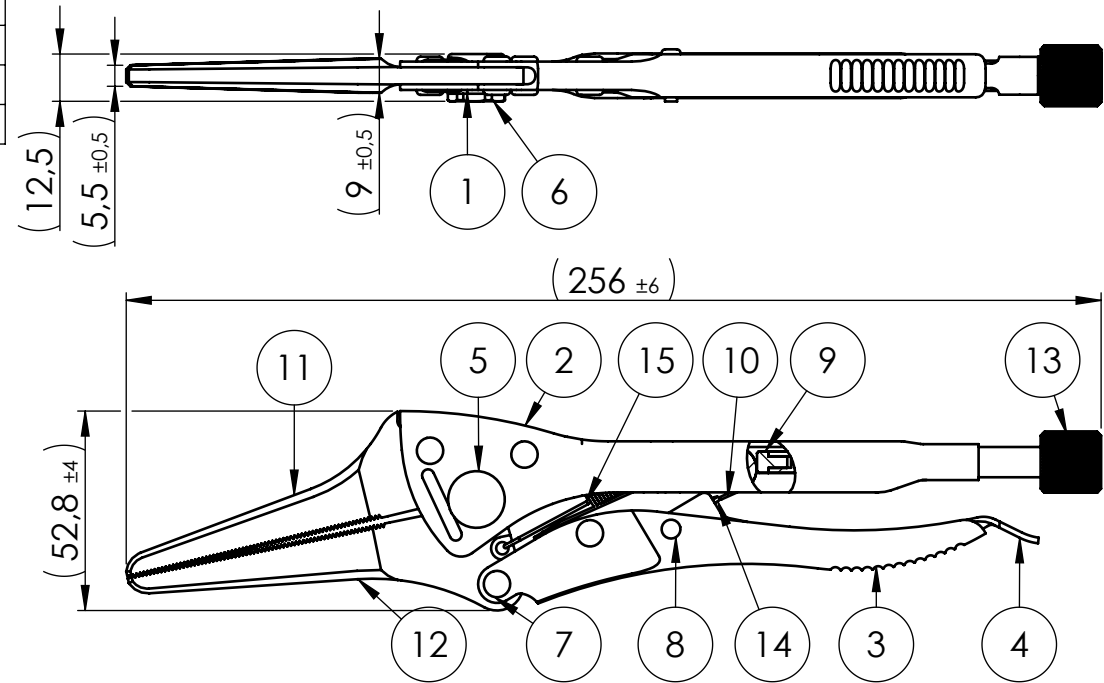

Branche beweglich (M1:1):

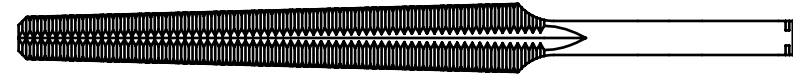

NON DISCLOSURE AGREEMENT

This drawing and / or specification contains information confidential and proprietary to SMT Schilling Metalltechnik GmbH Germany; and is conditionally loaned only. By retention, the receipt agrees not to reproduce or copy it in whole or in part, disclose any or all of its contents without prior written permission, or to make any use of it contrary to SMT Schilling Metalltechnik interest.

SMT - Werkzeichnung; entspricht nicht nach DIN

		(Zul. Abweich.) DIN ISO 2768m	(Oberfl.) siehe Einzelteile	Maßstab 1:2	Revision 00
Toleranzen (mm) DIN ISO 2768m		DIN 6 T1 Proj.methode 1		(Werkstoff, Halbzeug, Rohteil-Modell-Gesenk-Nr.) Material siehe Stückliste	
bis 6	6-30	30-120	120-400	400-1000	BENENNUNG: Spitzmaulzange mit Sonderstellschraube
± 0.1	± 0.2	± 0.3	± 0.5	± 0.8	
		DATUM	NAME		
		Erst.	11.07.2017	R.Schilling	
		Gep.	11.07.2017	A.Stuwe	
		Freig.	11.07.2017	E.Schilling	
00 Zeichnung erstellt.		11.07.17	RSCH	ZEICHNUNGSNR. 30-01-25-1614	
Zust.	Änderung	DATUM	NAME	Blatt 1 1 VON 1	