

Pos-Nr.	Menge	Art.Nummer	Benennung	Material	Revision
1	1	30-01-28-1604-01	Backen fest Sonderausf. 90° gebogen	1.4021	B
2	1	30-01-28-1604-02	Backen beweglich Sonderausf. 90° gebogen	1.4021	A
3	1	30-01-24-1601-03	Branche fest	1.4301	A
4	1	30-01-24-1601-04	Branche beweglich	1.4301	A
5	1	30-01-24-1601-05	Lösehebel	1.4301	A
6	1	30-01-24-1601-06	Mittelteil	1.4021	A
7	1	30-01-24-1601-07	Stellschraube	1.4305	A
8	1	30-01-24-1601-08	Gelenkschraube	1.4404	A
9	1	30-01-24-1601-09	Unterlegscheibe	1.4301	B
10	1	30-01-24-1601-10	Mutter	1.4305	A
11	4	30-01-24-1601-11	Bundniete 16,3 x 6	1.4301	A
12	1	30-01-24-1601-12	Bundniete 19,5xØ4	1.4301	A
13	1	3000650	Schenkelfeder 1,0 x 5,2 DiX 2,2	1.4310	A
14	1	13000653	Zugfeder mit Öhsen	1.4310	-

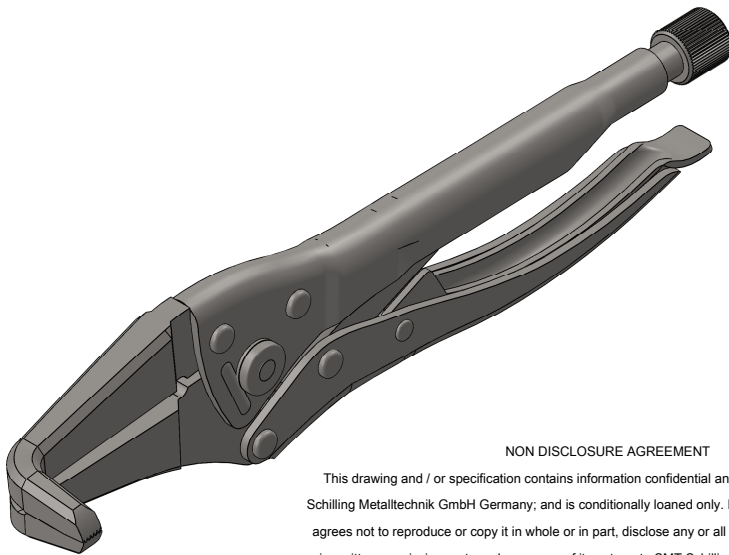
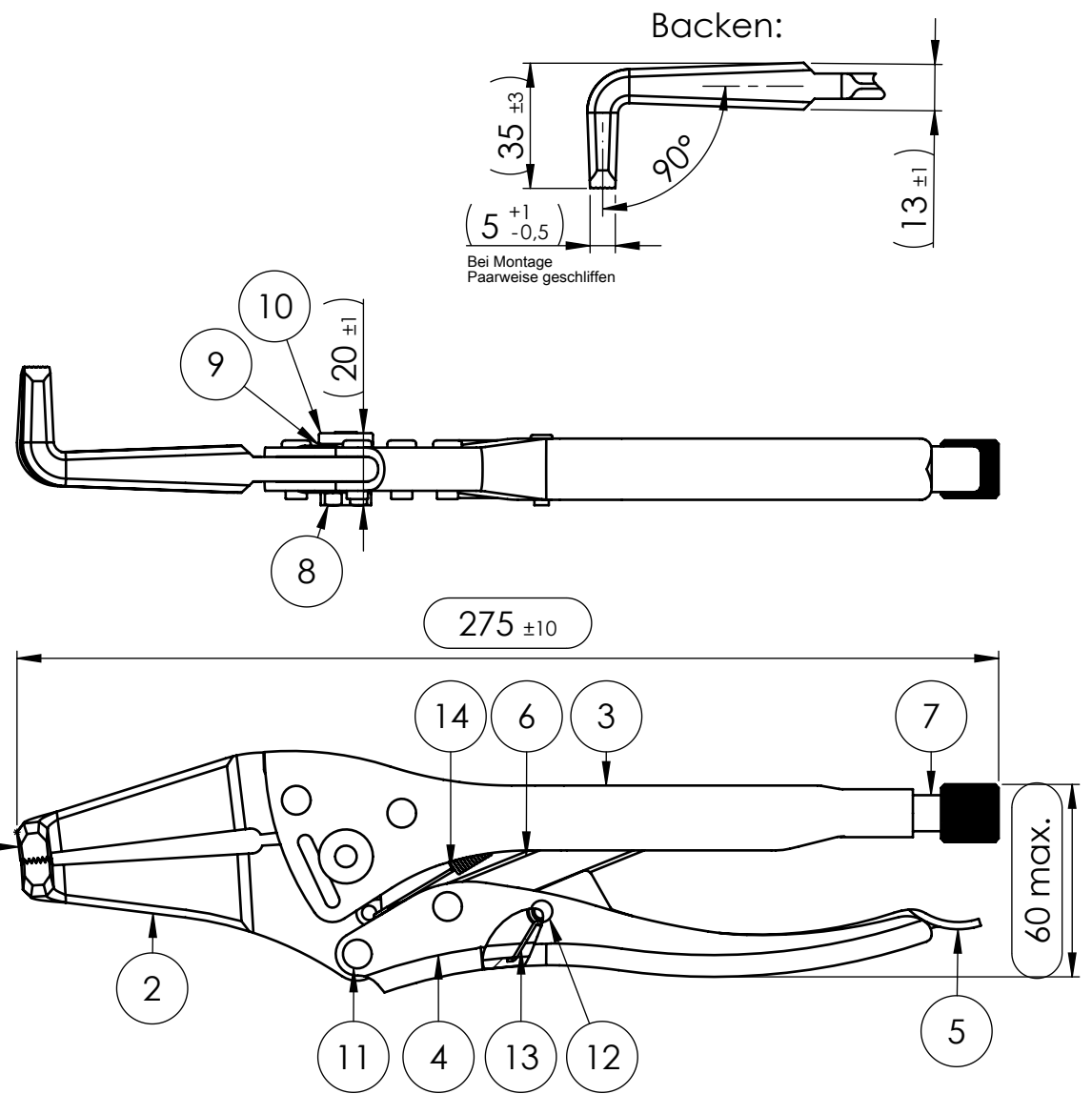

NON DISCLOSURE AGREEMENT

This drawing and / or specification contains information confidential and proprietary to SMT Schilling Metalltechnik GmbH Germany; and is conditionally loaned only. By retention, the receipt agrees not to reproduce or copy it in whole or in part, disclose any or all of its contents without prior written permission, or to make any use of it contrary to SMT Schilling Metalltechnik interest.

SMT - Werkszeichnung; entspricht nicht nach DIN

		(Zul. Abweich.) DIN ISO 2768m	(Oberfl.) Glasperl- gestrahlt	Maßstab 1:2 (Werkstoff, Halbzeug, Rohteil-Modell-Gesenk-Nr.) Material siehe Stückliste	Revision B
Toleranzen (mm) DIN ISO 2768m					
bis 6	6-30	30-120	120-400	400-1000	
± 0.1	± 0.2	± 0.3	± 0.5	± 0.8	
		DIN 6 T1 Proj.methode 1		BENENNUNG:	
		DATUM	NAME	Sonder Spitzmaul- feststellzange groß	
		Erst. 13.07.2017	R.Schilling		
		Gep. 13.07.2017	A.Stuwe		
		Freig. 13.07.2017	E.Schilling	ZEICHNUNGSNR. 30-01-28-1604	
A	Zeichnung erstellt.	13.07.17	RSCH	SMT Schilling Metalltechnik GmbH	
Zust.	Änderung	DATUM	NAME		
				Blatt 1 1 VON 1	