

Pos-Nr.	Menge	Art.Nummer	Benennung	Material	Revision
1	1	30-01-24-1601-03	Branche fest	1.4301	A
2	1	30-01-24-1601-04	Branche beweglich	1.4301	A
3	1	30-01-24-1601-05	Lösehebel	1.4301	A
4	1	30-01-24-1601-06	Mittelteil	1.4021	A
5	1	30-01-24-1601-07	Stellschraube	1.4305	A
6	4	30-01-24-1601-11	Bundniete 16,3 x 6	1.4301	A
7	1	30-01-24-1601-12	Bundniete 19,5xØ4	1.4301	A
8	1	30-01-28-1604-01	Backen fest Sonderausf. 90° gebogen	1.4021	B
9	1	30-01-28-1604-02	Backen beweglich Sonderausf. 90° gebogen	1.4021	A
10	1	30-01-40-1601-08	Mittelbolzen	1.4404	A
11	1	30-01-40-1601-09	Pressscheibe	1.4404	A
12	1	3000650	Schenkelfeder 1,0 x 5,2 DiX 2,2	1.4310	A
13	1	13000653	Zugfeder mit Öhsen	1.4310	-

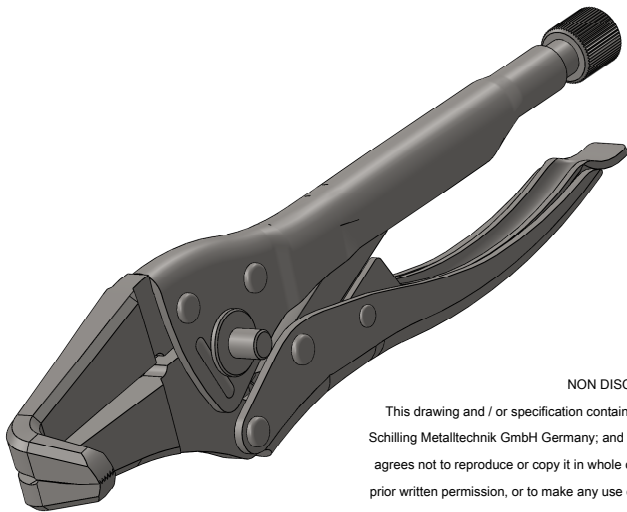
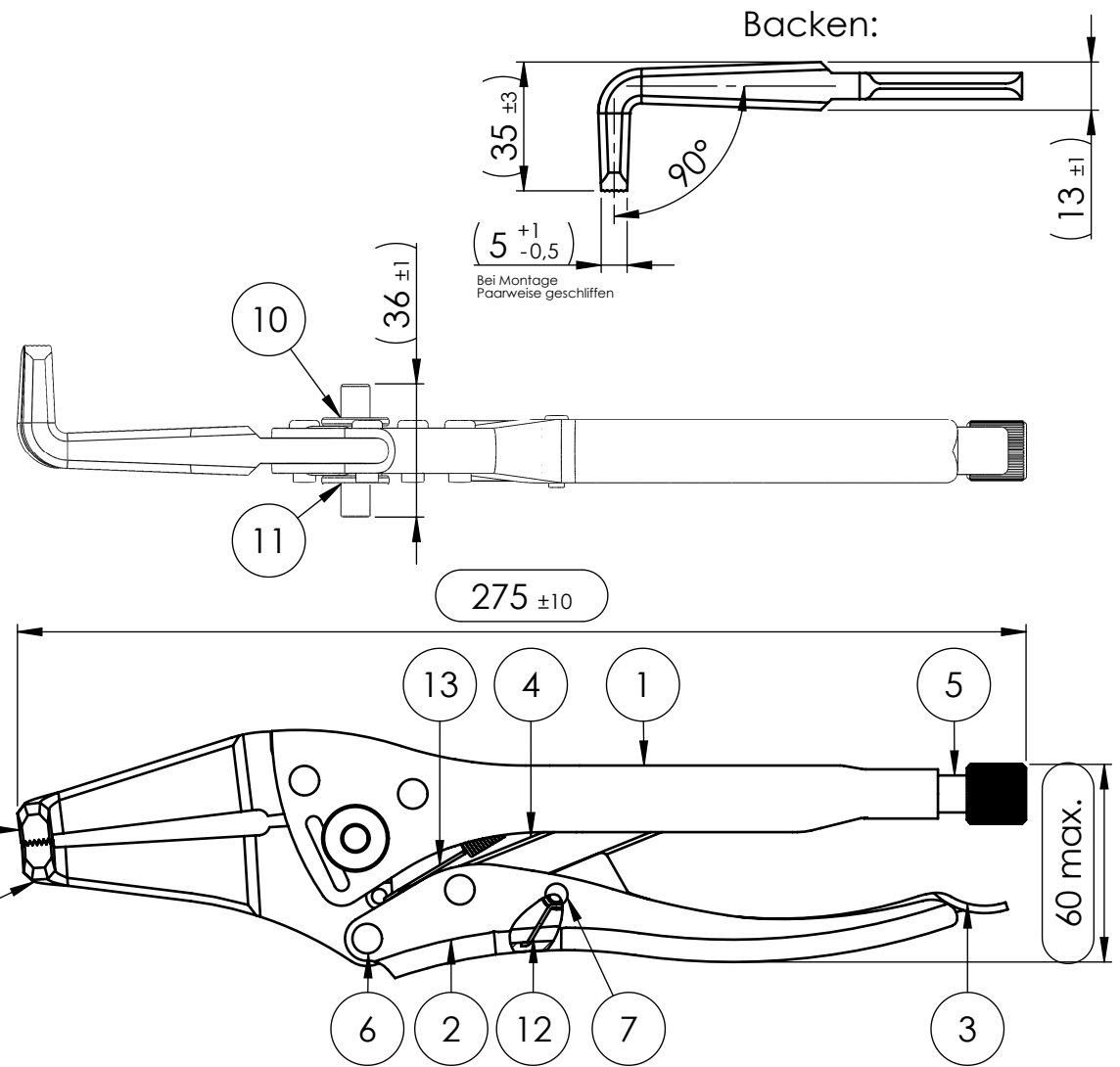

NON DISCLOSURE AGREEMENT

This drawing and / or specification contains information confidential and proprietary to SMT Schilling Metalltechnik GmbH Germany; and is conditionally loaned only. By retention, the receipt agrees not to reproduce or copy it in whole or in part, disclose any or all of its contents without prior written permission, or to make any use of it contrary to SMT Schilling Metalltechnik interest.

SMT - Werkszeichnung; entspricht nicht nach DIN

		(Zul. Abweich.) <b>DIN ISO 2768m</b>	(Oberfl.) Glasperl- gestrahlt	Maßstab 1:2	Revision B
Toleranzen (mm) DIN ISO 2768m		DIN 6 T1 Proj.methode 1		(Werkstoff, Halbzeug, Rohteil-Modell-Gesenk-Nr.) Material siehe Stückliste	
bis 6	6-30	30-120	120-400	400-1000	BENENNUNG:
± 0,1	± 0,2	± 0,3	± 0,5	± 0,8	<b>Sonder Spitzmaulfeststellzange groß umgebaut für Ausschlaghammer 700 Gramm</b>
		DATUM	NAME		
		Erst. 17.07.2017	R.Schilling		
		Gep. 17.07.2017	A.Stuwe		
		Freig. 17.07.2017	E.Schilling		
B	Zeichnung erstellt.	17.07.17	RSCH	ZEICHNUNGSNR. 30-01-28-1606	Blatt 1
Zust.	Änderung	DATUM	NAME	1 VON 1	