

Position	Menge	Bennennung	Artikel-Nr.	Material:	Revision
1	1	Hauptteil	30-02-28-1601-01	1.4021	A
2	1	Gelenkstück	30-02-28-1601-02	1.4021	A
3	1	Griffteil	30-02-28-1601-03	1.4021	A
4	1	Mittelteil	30-02-28-1601-04	1.4021	A
5	1	Spindelverbindung	30-02-28-1601-05	1.4021	A
6	1	Fixierschraube	30-02-28-1601-06	1.4404	A
7	1	Bolzen	30-02-28-1601-07	1.4021	A
8	1	Amboss groß	30-02-28-1601-08	1.4021	A
9	1	Stellrad	30-02-28-1601-09	1.4301	A
10	1	Spindel	30-02-28-1601-10	1.4305	A
11	1	Amboss klein	30-02-28-1601-11	1.4021	A
12	1	Hammer	30-02-28-1601-12	1.4021	A
13	1	Gewindehülse	30-02-28-1601-13	1.4404	A
14	1	Gegenführung	30-02-28-1601-14	POM	A
15	1	Anschlagstift	30-02-28-1601-15	1.4441	A
16	1	Pressstift	30-02-28-1601-16	1.4301	A
17	3	Schraube M3	69-40-01-1836	1.4404	A
18	1	Schraube M4	69-40-01-1839	1.4404	A
19	2	Verbindungshülse	69-42-01-1817	1.4021	A
20	1	Bolzen	69-42-01-1820	1.4021	A
21	1	Verbindungshülse	69-42-02-1807	1.4021	A
22	1	Gleitlager	A180FM-0608-06		A
23	2		KugelØ3	1.4034	A
24	2	Druckfeder	VD-090AE	1.4310	A

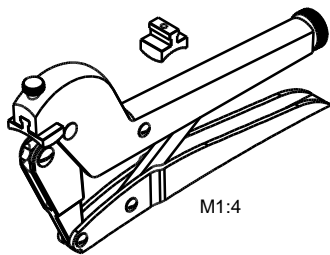
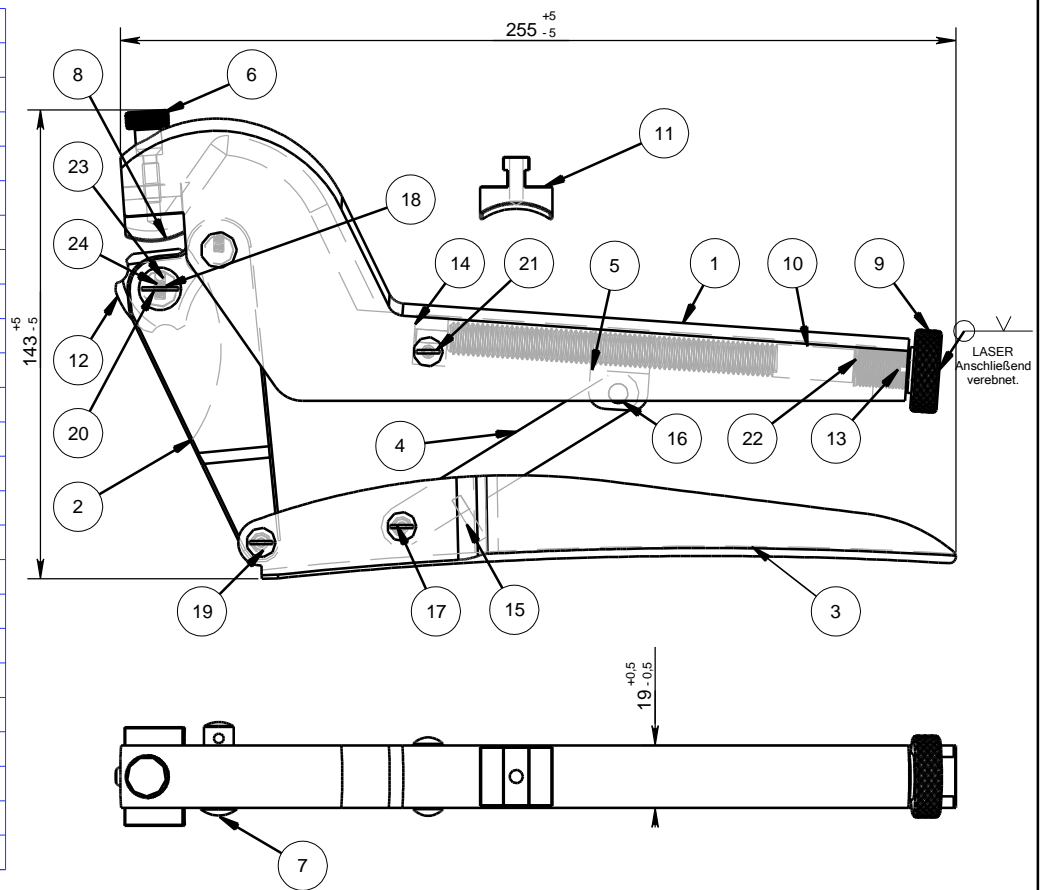

M1:4

NON DISCLOSURE AGREEMENT

This drawing and / or specification contains information confidential and proprietary to SMT Schilling Metalltechnik GmbH Germany, and is conditionally loaned only. By retention, the receipt, agrees not to reproduce or copy it in whole or in part, disclose any or all of its contents without prior written permission, or to make any use of it contrary to SMT Schilling Metalltechnik interest.

SMT - Werkszeichnung; entspricht nicht nach DIN

		(Zul. Abweich.)	(Oberfl.)	Maßstab 1:2	Revision A
		ISO 2768-m	Mattiert	(Werkstoff, Halbzeug, Rohteil- Modell- Gesenk-Nr.)	
		Datum	Name	Material Siehe Stückliste	
		Bearb. 01.02.13	A.Stuwe	(Benennung)	
		Gepf. 01.02.13	E.Schilling	Biegezange	
		Anzahl / Einheit:	1 St. 1	(Zeichnungsnummer)	
		SMT Schilling			30-02-28-1601
		Metalltechnik GmbH			Blatt 1
Zust.	Änderung	Datum	Name	Ers. für:	- Ers. durch: -