

Position	Menge	Bennennung	Artikel-Nr.	Material:	Revision
1	1	Klinge Phillips1 Stubby	30-06-01-1872-01	1.4034	A
2	1	Klingenaufnahme klein	69-23-02-2902-01	1.4301	A
3	1	Griff klein Stubby	69-23-04-2901-01	1.4301	A

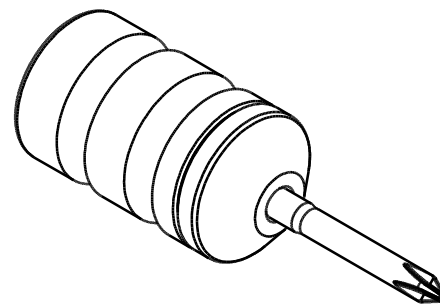
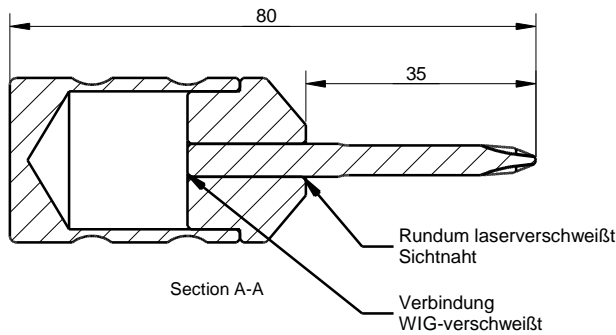
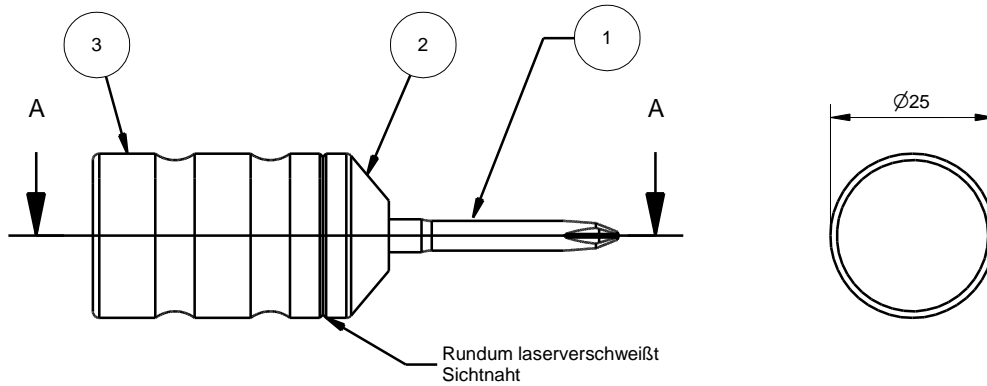

NON DISCLOSURE AGREEMENT

This drawing and / or specification contains information confidential and proprietary to SMT

Schilling Metalltechnik GmbH Germany, and is conditionally loaned only. By retention, the receipt

agrees not to reproduce or copy it in whole or in part, disclose any or all of its contents without

prior written permission, or to make any use of it contrary to SMT Schilling Metalltechnik interest.

SMT - Werkzeichnung; entspricht nicht nach DIN

	(Zul. Abweich.)	(Oberfl.)	Maßstab	1:1	Revision	A
	ISO 2768-m	Mattiert	(Werkstoff, Halbzeug, Rohteil- Modell- Gesenk-Nr.)			
			Material Siehe Einzelteile			
			(Benennung)			
			Phillips 1 Kurz-Schlitzschraubendreher, Klinge + Griff aus Edelstahl			
			(Zeichnungsnummer)			
			30-06-01-1872			Blatt 1
						Blätter
Zust.	Anderung	Datum	Name	Ers. für:	- Ers. durch: -	