

Pos-Nr.	Menge	Art.Nummer	Benennung	Material	Revision
1	1	30-06-02-1872-01	Klinge Phillips 2 Stubby	1.4034	A
2	1	73-01-05-2801-01	Griff groß Stubby	Propylux schwarz	A
3	1	69-42-03-5001-01	Stift groß	1.4301	A

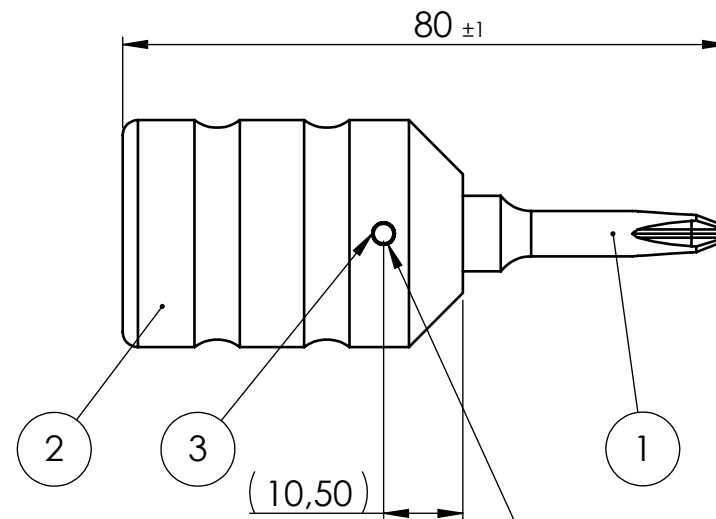

verstiftet bei Montage
Stift $\varnothing 3$

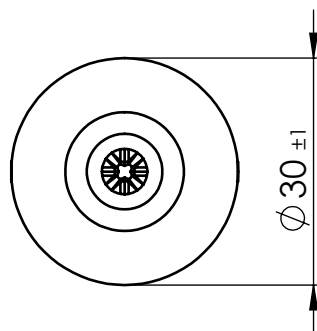
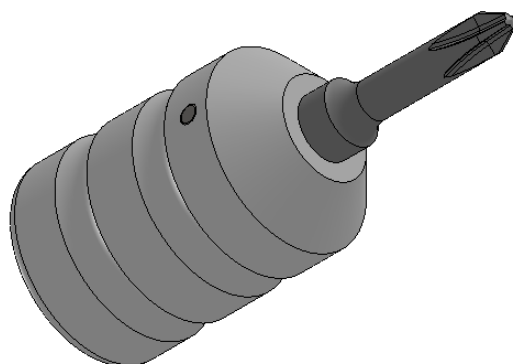

NON DISCLOSURE AGREEMENT

This drawing and / or specification contains information confidential and proprietary to SMT Schilling Metalltechnik GmbH Germany; and is conditionally loaned only. By retention, the receipt agrees not to reproduce or copy it in whole or in part, disclose any or all of its contents without prior written permission, or to make any use of it contrary to SMT Schilling Metalltechnik interest.

SMT - Werkzeichnung; entspricht nicht nach DIN

(Verwendungszweck) -		(Zul. Abweich.) DIN ISO 2768m	(Oberfl.) mattiert	Maßstab 1:1	Revision A												
Toleranzen (mm) DIN ISO 2768m				(Werkstoff, Halbzeug, Rohteil-Modell-Gesenk-Nr.) Material siehe Einzelteile -													
bis 6	6-30			30-120	120-400	400-1000	BENENNUNG: Phillips 2; Schraubendreher Klingenl.35mm Propyluxgriff										
$\pm 0,1$	$\pm 0,2$	$\pm 0,3$	$\pm 0,5$	$\pm 0,8$													
		<table border="1"> <thead> <tr> <th></th> <th>DATUM</th> <th>NAME</th> </tr> </thead> <tbody> <tr> <td>Erst.</td> <td>24.04.2014</td> <td>M.Diener</td> </tr> <tr> <td>Gep.</td> <td>24.04.2014</td> <td>Ovsjannikov</td> </tr> <tr> <td>Freig.</td> <td>24.04.2014</td> <td>E.Schilling</td> </tr> </tbody> </table>			DATUM	NAME	Erst.	24.04.2014	M.Diener	Gep.	24.04.2014	Ovsjannikov	Freig.	24.04.2014	E.Schilling		
	DATUM	NAME															
Erst.	24.04.2014	M.Diener															
Gep.	24.04.2014	Ovsjannikov															
Freig.	24.04.2014	E.Schilling															
A	Zeichnung erstellt.	24.04.14	DM	ZEICHNUNGSNR. 30-06-02-1877													
Zust.	Änderung	DATUM	NAME			Blatt 1 1 VON 1											
SMT Schilling Metalltechnik GmbH																	