

Pos-Nr.	Menge	Art.Nummer	Benennung	Material	Revision
1	1	30-06-03-1872-01	Klinge Phillips 3 Stubby	1.4034	A
2	1	73-01-05-2801-01	Griff groß Stubby	Propylux schwarz	A
3	1	69-42-03-5001-01	Stift groß	1.4301	A

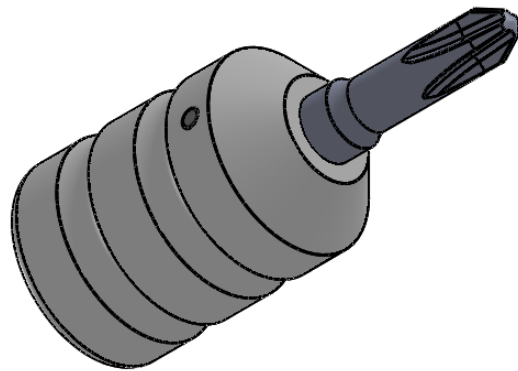
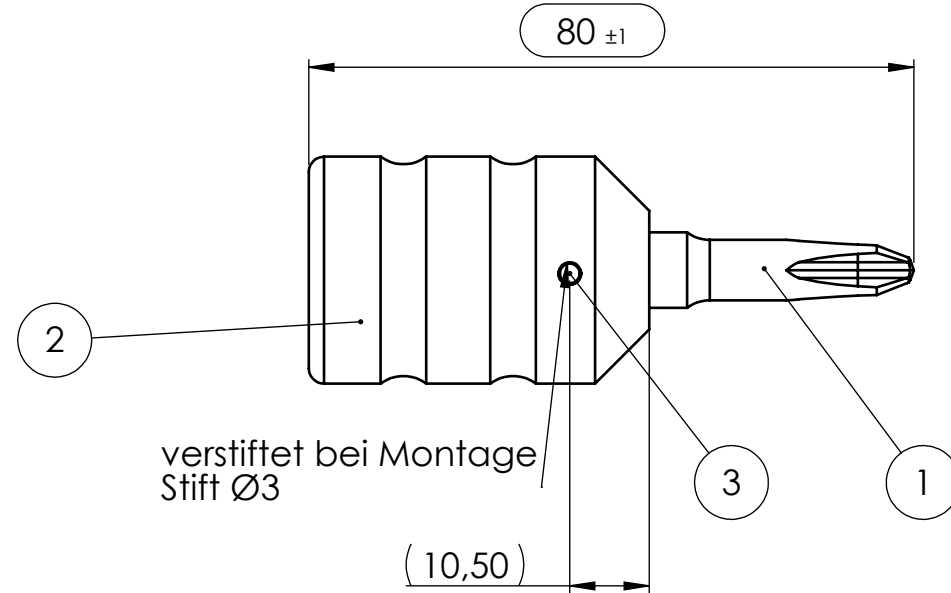
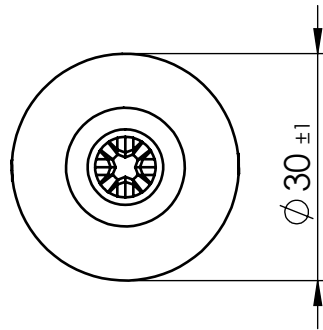

NON DISCLOSURE AGREEMENT

This drawing and / or specification contains information confidential and proprietary to SMT Schilling Metalltechnik GmbH Germany; and is conditionally loaned only. By retention, the receipt agrees not to reproduce or copy it in whole or in part, disclose any or all of its contents without prior written permission, or to make any use of it contrary to SMT Schilling Metalltechnik interest.

SMT - Werkszeichnung; entspricht nicht nach DIN

(Verwendungszweck)		(Zul. Abweich.)	(Oberfl.)	Maßstab 1:1	Revision A
-		DIN ISO 2768m	mattiert	(Werkstoff, Halbzeug, Rohteil-Modell-Gesenk-Nr.)	
Toleranzen (mm) DIN ISO 2768m				Material siehe Stückliste -	
bis 6	6-30			30-120	120-400
$\pm 0,1$	$\pm 0,2$	$\pm 0,3$	$\pm 0,5$	$\pm 0,8$	
		DATUM	NAME	Phillips 3; Schraubendreher Klingenl. 35mm; Propyluxgriff	
		Erst. 24.04.2014	M.Diener		
		Gep. 24.04.2014	Ovsjannikov		
		Freig. 24.04.2014	E.Schilling		
A	Zeichnung erstellt.	24.04.14	DM	SMT Schilling Metalltechnik GmbH	
Zust.	Änderung	DATUM	NAME		
				ZEICHNUNGSNR.	Blatt 1
				30-06-03-1877	1 VON 1