

Position	Menge	Benennung	Artikel-Nr.	Material:	Revision
1	1	Klinge 5mm	30-06-05-1861-01	1.4034	A
2	1	Stöpsel klein	69-23-01-2900-01	1.4301	A
3	1	Griffrohr klein	69-23-09-2900-01	1.4301	A
4	1	Klingenaufnahme klein	69-23-02-2902-01	1.4301	A

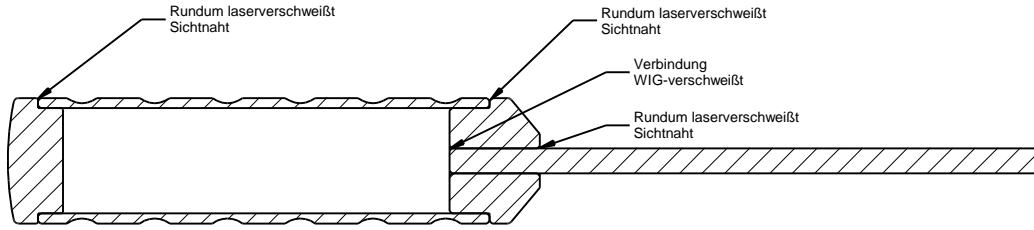

Section A-A

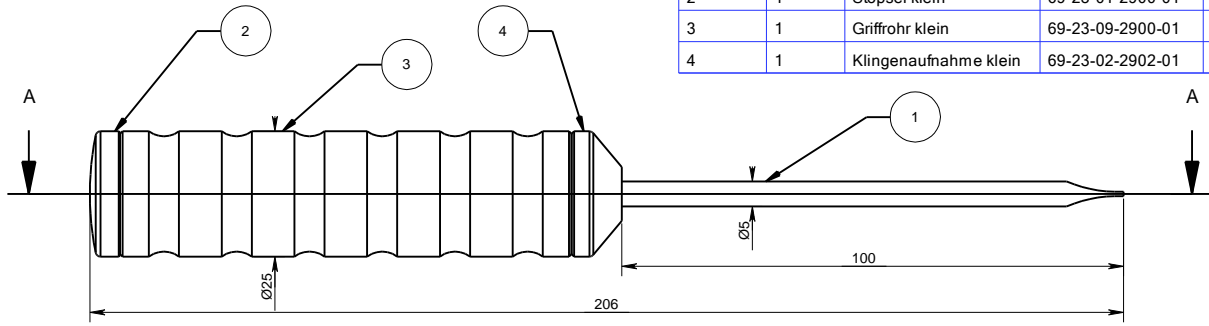
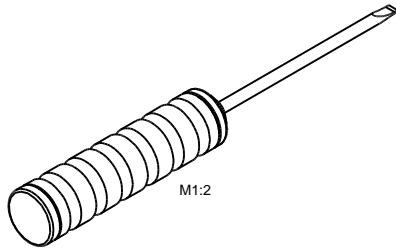

NON DISCLOSURE AGREEMENT

This drawing and / or specification contains information confidential and proprietary to SMT Schilling Metalltechnik GmbH Germany, and is conditionally loaned only. By retention, the receipt agrees not to reproduce or copy it in whole or in part, disclose any or all of its contents without prior written permission, or to make any use of it contrary to SMT Schilling Metalltechnik interest. SMT - Werkzeichnung; entspricht nicht nach DIN

		(Zul. Abweich.)	(Oberfl.)	Maßstab 1:1	Revision A
		ISO 2768-m	Mattiert	(Werkstoff, Halbzeug, Rohteil- Modell- Gesenk-Nr.)	
		Datum	Name	Material Siehe Einzelteilzeichnungen	
		Bearb: 04.07.12	A. Stuwe	(Benennung)	
		Gepr: 04.07.12	E. Schilling	5mm Schlitzschraubendreher	
		Anzahl / Einheit:	1 St. 1	(Zeichnungsnummer)	
		SMT Schilling Metalltechnik GmbH			30-06-05-1861
Zust.	Änderung	Datum	Name	Urspr.	Ers. für: - Ers. durch: -
					Blatt 1
					Blätter -