

Größe	Artikelnummer	A
T5	30-06-05-1858	Ø5
T6	30-06-06-1858	Ø5
T7	30-06-07-1858	Ø5
T8	30-06-08-1858	Ø5
T9	30-06-09-1858	Ø5
T10	30-06-10-1858	Ø5
T15	30-06-15-1858	Ø5
T20	30-06-20-1858	Ø5
T25	30-06-25-1858	Ø5
T27	30-06-27-1858	Ø6
T30	30-06-30-1858	Ø6
T40	30-06-40-1858	Ø7
T45	30-06-45-1858	Ø8
T50	30-06-50-1858	Ø9

Pos-Nr.	Menge	Art.Nummer	Benennung	Material	Revision
1	1	30-06-08-1837-01	Klinge T8	1.4021	A
2	1	73-01-11-2800-01	Griff klein	Propylux schwarz	A
3	1	69-42-03-5000-01	Stift Ø2,5	1.4301	A

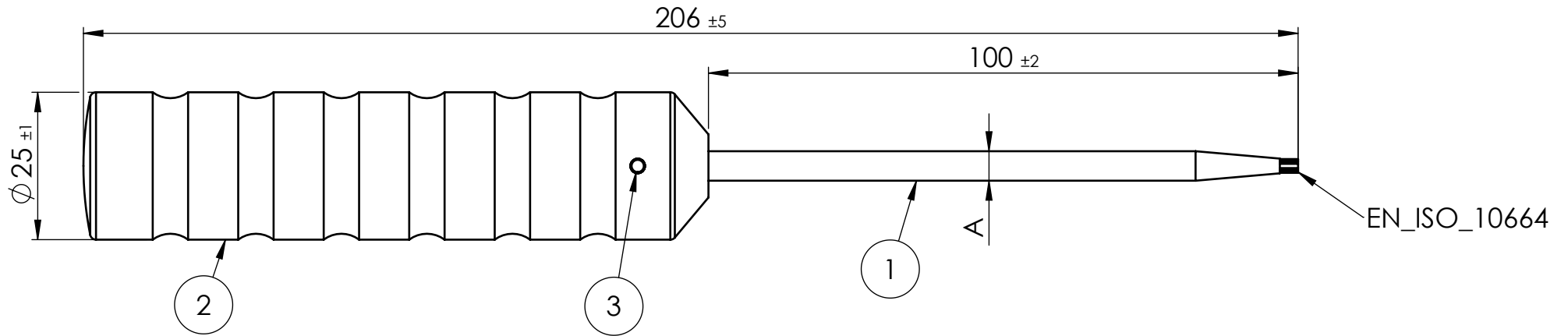

NON DISCLOSURE AGREEMENT
 This drawing and / or specification contains information confidential and proprietary to SMT Schilling Metalltechnik GmbH Germany; and is conditionally loaned only. By retention, the receipt agrees not to reproduce or copy it in whole or in part, disclose any or all of its contents without prior written permission, or to make any use of it contrary to SMT Schilling Metalltechnik interest.
 SMT - Werkszeichnung; entspricht nicht nach DIN

		(Zul. Abweich.)	Maßstab 1:1		Revision A
		DIN ISO 2768m	(Werkstoff, Halbzeug, Rohteil-Modell-Gesenk-Nr.)		
Toleranzen (mm) DIN ISO 2768m		Material Siehe Stückliste			
bis 6	6-30	30-120	120-400	400-1000	BENENNUNG: Sechsrund Schraubendreher mit Kunststoffgriff Klingenlänge 100mm
± 0.1	± 0.2	± 0.3	± 0.5	± 0.8	
		DIN 6 T1 Proj.methode 1			
		DATUM	NAME		
		Erst.	14.10.2015	R.Schilling	
		Gep.	14.10.2015	A.Stuwe	
		Freig.	14.10.2015	E.Schilling	
A	Zeichnung erstellt.	14.10.15	RSCH	ZEICHNUNGSNR. 30-06-08-1858_Tabelle	
Zust.	Änderung	DATUM	NAME		
SMT Schilling Metalltechnik GmbH				Blatt 1 1 VON 1	