

Artikelnummer	A ( $\pm 1$ )	B (h9)	C	D
30-06-03-1876	$\varnothing 25$	$\varnothing 5$	2,95	0,5
30-06-04-1876	$\varnothing 25$	$\varnothing 5$	3,95	0,8
30-06-05-1876	$\varnothing 25$	$\varnothing 5$	4,9	0,9
30-06-06-1876	$\varnothing 30$	$\varnothing 10$	5,9	1,2
30-06-08-1876	$\varnothing 30$	$\varnothing 10$	7,95	1,2
30-06-10-1876	$\varnothing 30$	$\varnothing 10$	9,9	1,6

Pos-Nr.	Menge	Art.Nummer	Benennung	Material	Revision
1	1	30-06-08-1871-01	Klinge 8mm Stubby	1.4034	A
2	1	73-01-05-2801-01	Griff groß Stubby	Propylux schwarz	A
3	1	69-42-03-5001-01	Stift groß	1.4301	A

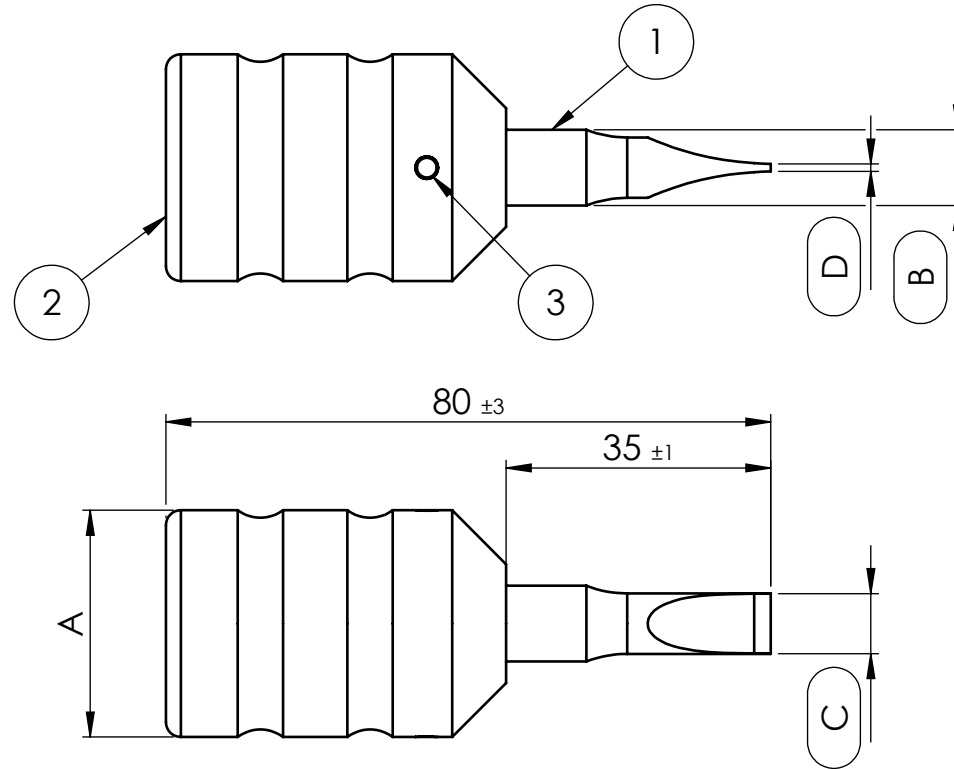

NON DISCLOSURE AGREEMENT

This drawing and / or specification contains information confidential and proprietary to SMT Schilling Metalltechnik GmbH Germany; and is conditionally loaned only. By retention, the receipt agrees not to reproduce or copy it in whole or in part, disclose any or all of its contents without prior written permission, or to make any use of it contrary to SMT Schilling Metalltechnik interest.

SMT - Werkszeichnung; entspricht nicht nach DIN

		(Zul. Abweich.)	Maßstab 1:1		Revision A
		<b>DIN ISO 2768m</b>	(Werkstoff, Halbzeug, Rohteil-Modell-Gesenk-Nr.)		
Toleranzen (mm) DIN ISO 2768m		Material siehe Stückliste		BENENNUNG:	
bis 6	6-30	30-120	120-400	400-1000	<b>Schrittschraubendreher mit Kunststoffgriff Klingenlänge: 35mm</b>
$\pm 0,1$	$\pm 0,2$	$\pm 0,3$	$\pm 0,5$	$\pm 0,8$	
		DIN 6 T1 Proj.methode 1			
		DATUM	NAME		
		Erst.	07.10.2015	R.Schilling	
		Gep.	07.10.2015	A.Stuwe	
		Freig.	07.10.2015	E.Schilling	
		<b>SMT Schilling</b>		ZEICHNUNGSNR.	
		<b>Metalltechnik GmbH</b>		30-06-08-1876_Tabelle	
A	Zeichnung erstellt.	07.10.15	RSCH	Blatt 1	
Zust.	Änderung	DATUM	NAME	1 VON 1	