

Pos-Nr.	Menge	Art.Nummer	Benennung	Material	Revision
1	1	30-06-11-1862-01	Klinge Pozi 1	1.4034	A
2	1	69-23-01-2900-01	Stöpsel klein	1.4301	A
3	1	69-23-09-2900-01	Griffrohr klein	1.4301	A
4	1	69-23-02-2902-01	Klingenaufnahme klein	1.4301	A

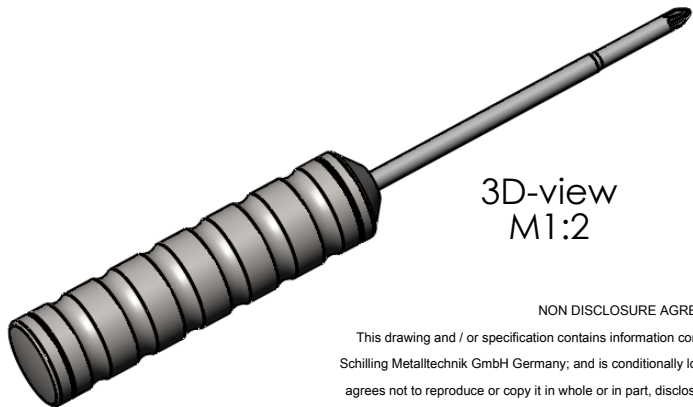
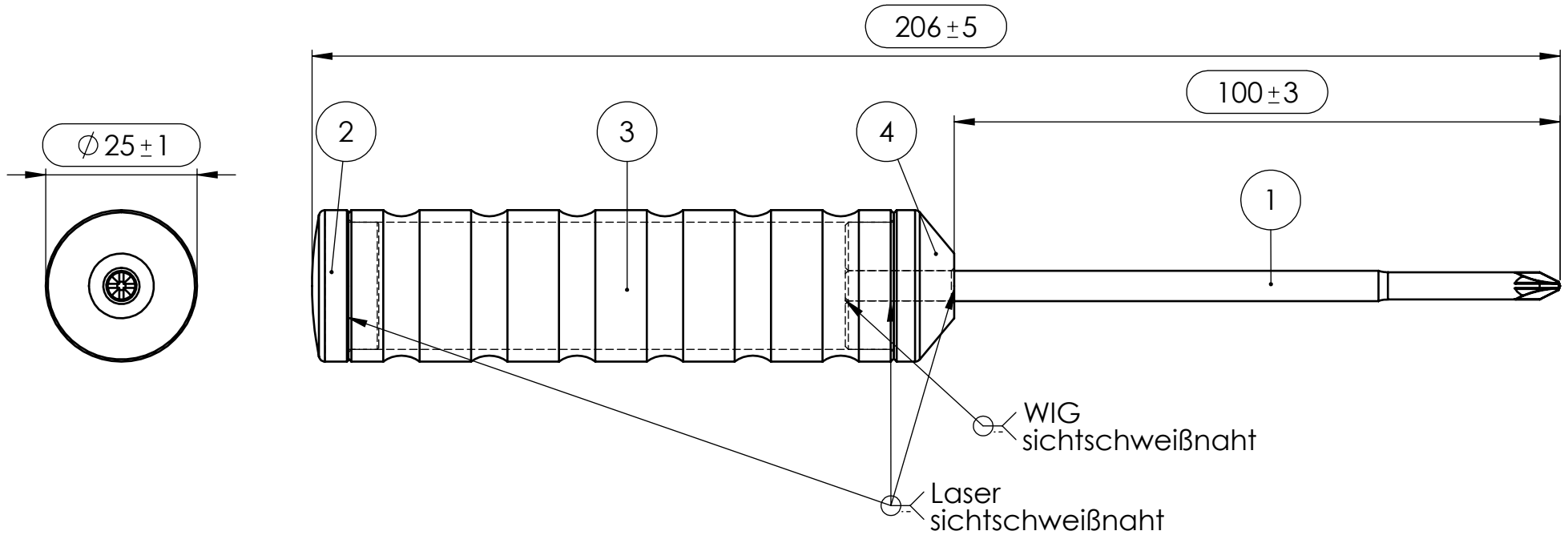

3D-view
M1:2

NON DISCLOSURE AGREEMENT

This drawing and / or specification contains information confidential and proprietary to SMT Schilling Metalltechnik GmbH Germany; and is conditionally loaned only. By retention, the receipt agrees not to reproduce or copy it in whole or in part, disclose any or all of its contents without prior written permission, or to make any use of it contrary to SMT Schilling Metalltechnik interest.

SMT - Werkzeichnung; entspricht nicht nach DIN

		(Zul. Abweich.) DIN ISO 2768m	(Oberfl.) Siehe Einzelteile	Maßstab 1:1 (Werkstoff, Halbzeug, Rohteil-Modell-Gesenk-Nr.)	Revision A
Toleranzen (mm) DIN ISO 2768m				Material Siehe Stückliste	
bis 6	6-30	30-120	120-400	BENENNUNG:	
± 0,1	± 0,2	± 0,3	± 0,5	Pozidriv 1	
				ZEICHNUNGSNR.	
				30-06-11-1862	
				Blatt 1	
				1 VON 1	