

Pos-Nr.	Menge	Art.Nummer	Benennung	Material	Revision
1	1	30-06-12-1862-01	Klinge Pozi 2	1.4034	A
2	1	69-23-12-2900-01	Griffrohr groß	1.4301	A
3	1	69-23-01-2901-01	Stöpsel groß	1.4301	A
4	1	69-23-02-2901-01	Klingenaufnahme groß	1.4301	A

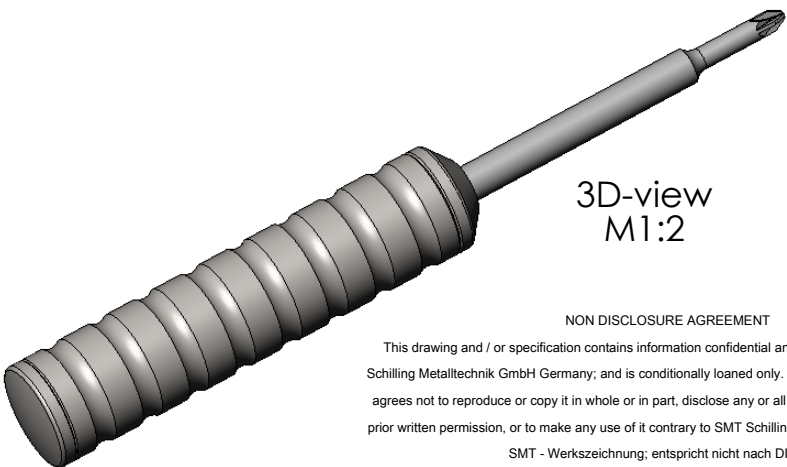
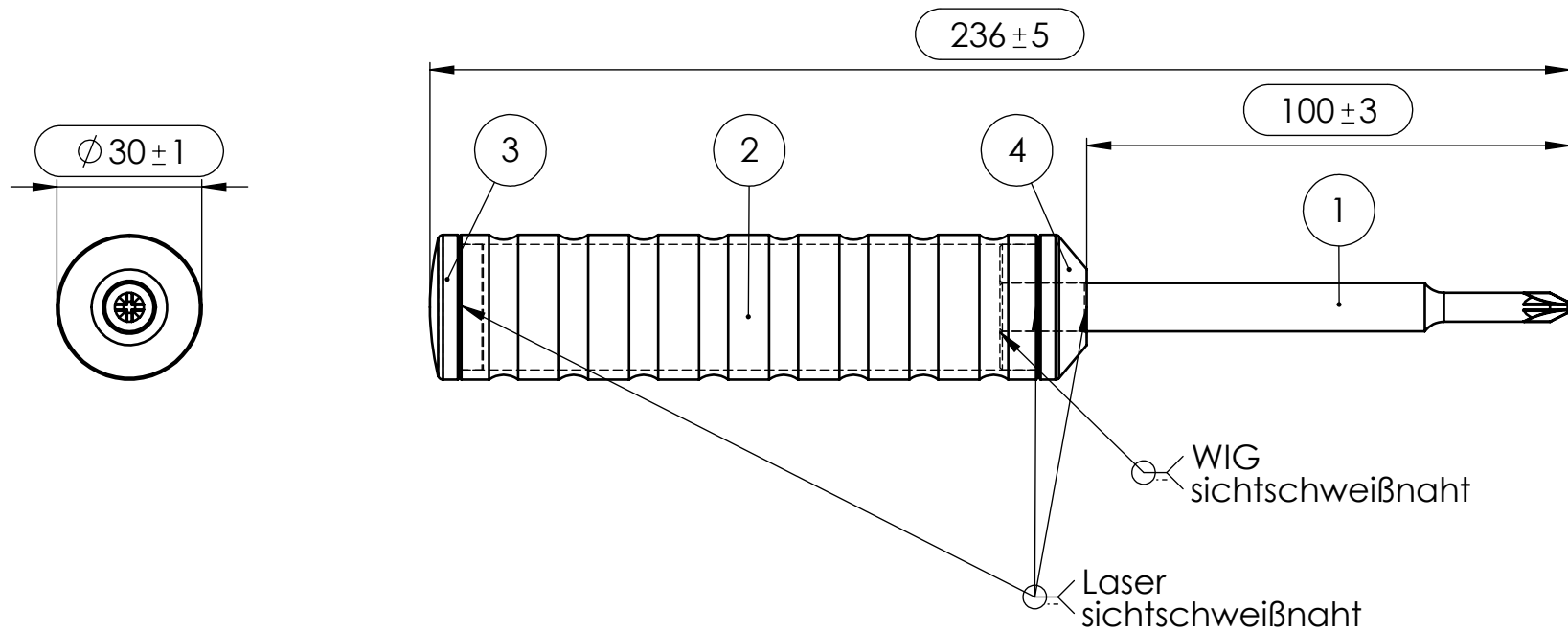

3D-view
M1:2

NON DISCLOSURE AGREEMENT

This drawing and / or specification contains information confidential and proprietary to SMT Schilling Metalltechnik GmbH Germany; and is conditionally loaned only. By retention, the receipt agrees not to reproduce or copy it in whole or in part, disclose any or all of its contents without prior written permission, or to make any use of it contrary to SMT Schilling Metalltechnik interest.

SMT - Werkzeichnung; entspricht nicht nach DIN

		(Zul. Abweich.) DIN ISO 2768m	(Oberfl.) Siehe Einzelteile	Maßstab 1:1,5 (Werkstoff, Halbzeug, Rohteil-Modell-Gesenk-Nr.) Material Siehe Stückliste	Revision A
Toleranzen (mm) DIN ISO 2768m				BENENNUNG:	
bis 6	6-30	30-120	120-400	400-1000	<h1>Pozidriv 2</h1>
± 0,1	± 0,2	± 0,3	± 0,5	± 0,8	
		DATUM		NAME	
		Erst. 05.06.2014		A.Stuwe	
		Gep. 05.06.2014		Ovsjannikov	
		Freig. 05.06.2014		E.Schilling	
A		Zeichnung erstellt.		05.06.14 STA	
Zust.		Änderung		DATUM NAME	
				SMT Schilling Metalltechnik GmbH	
				ZEICHNUNGSNR. 30-06-12-1862	
				Blatt 1 1 VON 1	