

| Pos-Nr. | Menge | Art.Nummer | Benennung | Material | Revision |
|---------|-------|------------------|-------------------|------------------|----------|
| 1 | 1 | 30-06-12-1872-01 | Klinge Pozi 2 | 1.4034 | A |
| 2 | 1 | 73-01-05-2801-01 | Griff groß Stubby | Propylux schwarz | A |
| 3 | 1 | 69-42-03-5001-01 | Stift groß | 1.4301 | A |

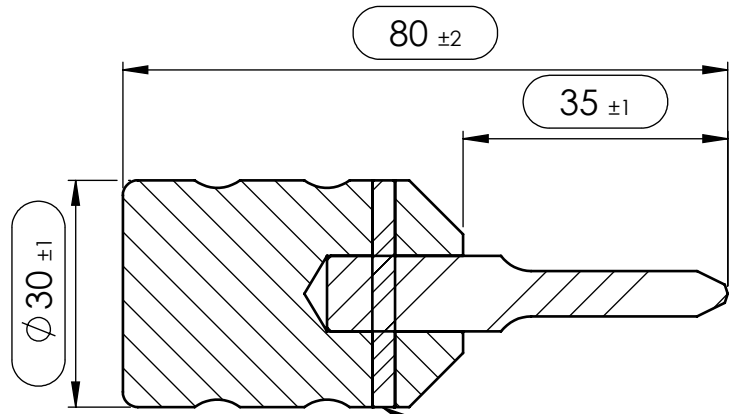

SCHNITT A-A verstitet bei Montage

POZI-Form nach DIN ISO 8764-1

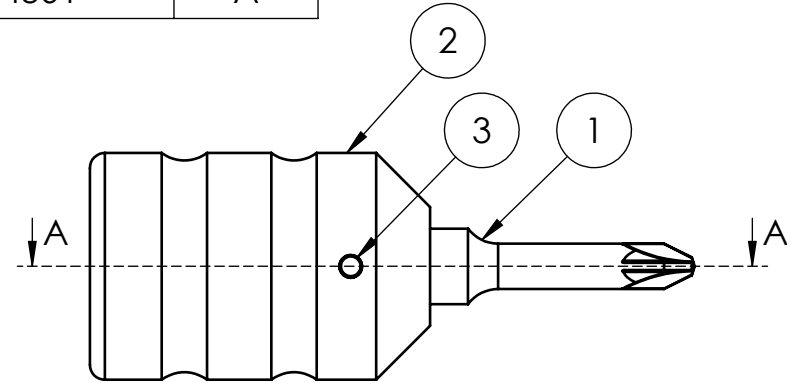
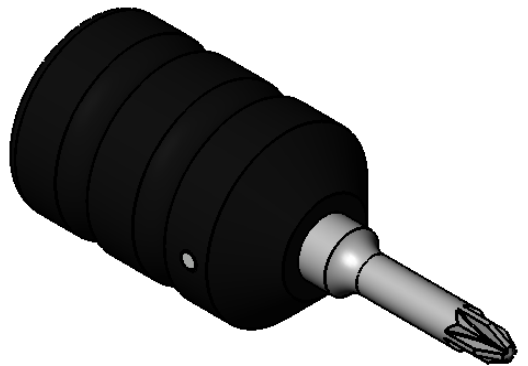

NON DISCLOSURE AGREEMENT

This drawing and / or specification contains information confidential and proprietary to SMT Schilling Metalltechnik GmbH Germany; and is conditionally loaned only. By retention, the receipt agrees not to reproduce or copy it in whole or in part, disclose any or all of its contents without prior written permission, or to make any use of it contrary to SMT Schilling Metalltechnik interest.

SMT - Werkszeichnung; entspricht nicht nach DIN

| | | | | | |
|-------------------------------|-------|---|--------------------------------|---|------------|
| | | (Zul. Abweich.) DIN ISO 2768m | (Oberfl.) siehe Einzelteile | Maßstab 1:1 (Werkstoff, Halbzeug, Rohteil-Modell-Gesenk-Nr.) | Revision A |
| Toleranzen (mm) DIN ISO 2768m | | DIN 6 T1 Proj.methode 1 | | Material siehe Einzelteile | |
| bis 6 | 6-30 | 30-120 | 120-400 | 400-1000 | |
| ± 0.1 | ± 0.2 | ± 0.3 | ± 0.5 | ± 0.8 | |
| | | DATUM | NAME | BENENNUNG: | |
| | | Erst. | 08.07.2015 | R.Schilling | |
| | | Gep. | 08.07.2015 | A.Stuwe | |
| | | Freig. | 08.07.2015 | E.Schilling | |
| A | | Zeichnung erstellt. | | 08.07.15 | |
| Zust. | | Änderung | | RSCH | |
| | | DATUM | | NAME | |
| | | SMT Schilling | | ZEICHNUNGSNR. | |
| | | Metalltechnik GmbH | | 30-06-12-1877 | |
| | | | | | Blatt 1 |
| | | | | | 1 VON 1 |