

Position	Menge	Bennennung	Artikel-Nr.	Material:	Revision
1	1	Spindel	30-06-17-1600-01	1.4021	A
2	1	Gelenkverbindung	30-06-17-1600-03	1.4021	A
3	1	Griffstange	30-06-17-1600-04	1.4021	A
4	2	Stift	30-06-17-1600-05	1.4404	A
5	1	Sechskantschl. SW6	30-06-21-1600-01	1.4112	A

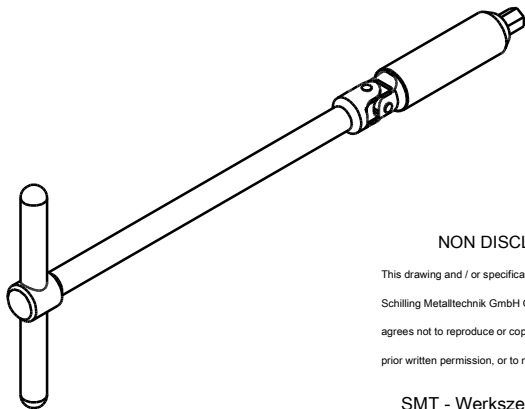
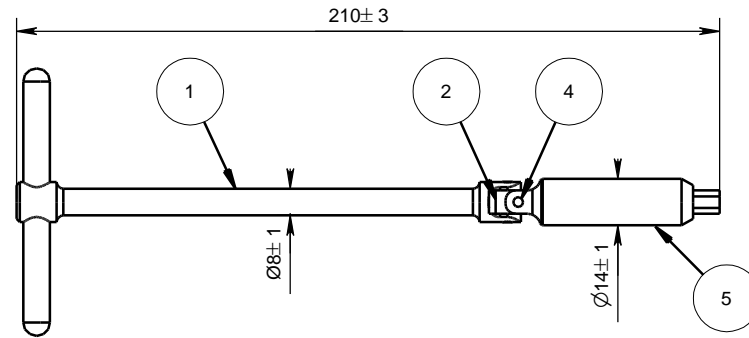
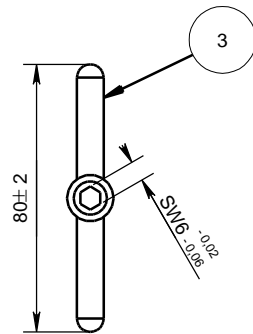

NON DISCLOSURE AGREEMENT

This drawing and / or specification contains information confidential and proprietary to SMT Schilling Metalltechnik GmbH Germany, and is conditionally loaned only. By retention, the receipt agrees not to reproduce or copy it in whole or in part, disclose any or all of its contents without prior written permission, or to make any use of it contrary to SMT Schilling Metalltechnik interest.

SMT - Werkszeichnung; entspricht nicht nach DIN

		(Zul. Abweich.)	(Oberfl.)	Maßstab	1:2	Revision	A
		ISO 2768-m	Mattiert	(Werkstoff, Halbzeug, Rohteil- Modell- Gesenk-Nr.)			
				Material Siehe Einzelteilzeichnungen			
				(Benennung)			
				T-Griff Steckschlüssel SW6 mit Kardangelen			
				(Zeichnungsnummer)			
				30-06-20-1803			
				Blatt 1			
				Blätter			
A	Zeichnung erstellt.	24.02.12	STA	SMT Schilling Metalltechnik GmbH			
Zust.	Anderung	Datum	Name				