

Menge	Art.Nummer	Benennung	Material	Revision
1	30-06-92-1832-01	1/2" Vierkant-Schraubendreher 100mm Länge	1.4021	A
1	Kugel_Ø6	Kugel Edelstahl	1.4034	A
1	VD_117A	Druckfeder 117A	1.4310	A
1	69-42-03-5001-01	Stift	1.4301	A
1	73-01-14-2800-01	Griff	Propylux	A

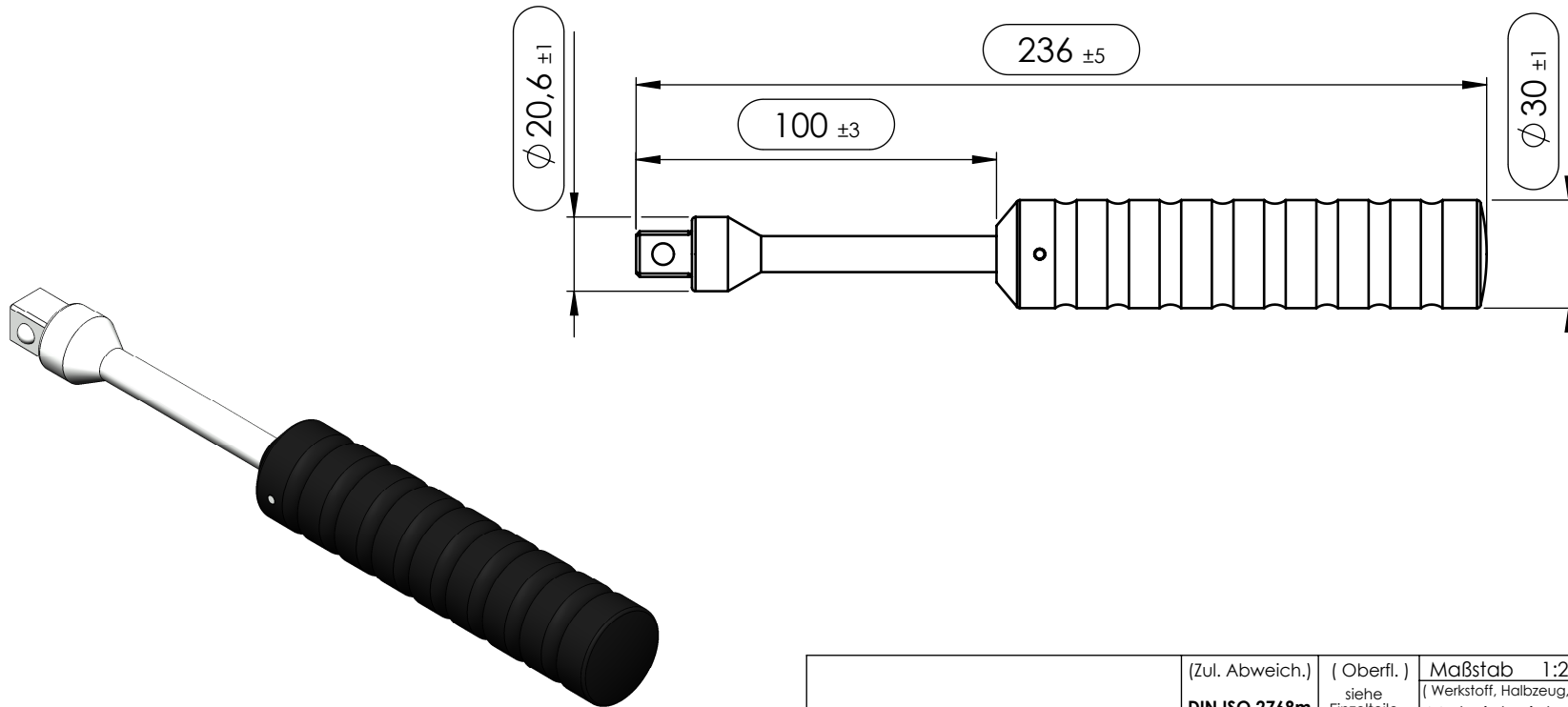

NON DISCLOSURE AGREEMENT

This drawing and / or specification contains information confidential and proprietary to SMT Schilling Metalltechnik GmbH Germany; and is conditionally loaned only. By retention, the receipt agrees not to reproduce or copy it in whole or in part, disclose any or all of its contents without prior written permission, or to make any use of it contrary to SMT Schilling Metalltechnik interest.

SMT - Werkszeichnung; entspricht nicht nach DIN

		(Zul. Abweich.) <b>DIN ISO 2768m</b>	(Oberfl.) siehe Einzelteile	Maßstab 1:2	Revision A
Toleranzen (mm) DIN ISO 2768m				(Werkstoff, Halbzeug, Rohteil-Modell-Gesenk-Nr.)	
bis 6	6-30	30-120	120-400	400-1000	Material siehe Einzelteile
± 0.1	± 0.2	± 0.3	± 0.5	± 0.8	BENENNUNG:
				1/2" Vierkant-Schraubendreher 100mm Länge mit Propyluxgriff	
				ZEICHNUNGSNR.	
				30-06-92-1860	
				Blatt 1	
				1 VON 1	

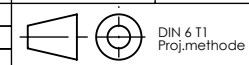

	DATUM	NAME
Erst.	13.07.2015	R.Schilling
Gep.	13.07.2015	A.Stuwe
Freig.	13.07.2015	E.Schilling

**SMT Schilling**  
Metalltechnik GmbH