

Section A-A

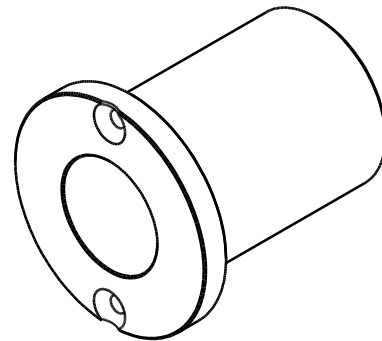

NON DISCLOSURE AGREEMENT

This drawing and / or specification contains information confidential and proprietary to SMT Schilling Metalltechnik GmbH Germany, and is conditionally loaned only. By retention, the recipient agrees not to reproduce or copy it in whole or in part, disclose any or all of its contents without prior written permission, or to make any use of it contrary to SMT Schilling Metalltechnik interest.

SMT - Werkzeichnung entspricht nicht nach DIN

(Verwendungszweck)		(Zul. Abweich.)	(Oberfl.)	Maßstab	1:1	Revision	A
Knochenmühle		ISO 2768-m		(Werkstoff, Halbzeug, Rohteil- Modell- Gesenk-Nr.)			
				Material Teflon_ weiss			
			Datum	Name	(Benennung)		
			Bearb.	03.04.12	A. Stuwe	Lagerbuchse	
			Gepr.	03.04.12	E. Schilling		
			Anzahl / Einheit:		1	St.	1
		SMT Schilling			(Zeichnungsnummer)		
		Metalltechnik GmbH			52-03-42-2401-04		
Zust.	Anderung	Datum	Name	Ers. für:	- Ers. durch:		Blatt
							1
							Blätter
							-